



MEASURING

MULTI-LAYER

LIQUID

DEPTHS

WITH

TDR

SEE PAGE 7

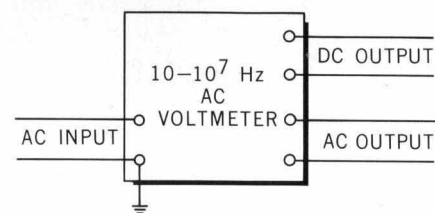

**A NEW AC VOLTMETER WITH  
GROUND-REFERENCED DC OUTPUT; P. 2**

# A NEW HIGH-STABILITY AC VOLTMETER WITH A 10-MHz FREQUENCY RANGE AND 1% ACCURACY

A new ac voltmeter with wide frequency coverage and enhanced accuracy is the first of its type to achieve a ground-referenced dc output.

NEW INSTRUMENTATION is most often based on new concepts that advance or simplify more rudimentary methods. Sometimes, however, an advance in instrumentation is possible because of the availability of new and improved circuit components.

Such is the case with a major new broadband ac voltmeter developed recently in the *-hp-* Loveland laboratories. The new voltmeter measures with enhanced accuracy over a specified frequency range that is more than double that of existing *-hp-* sensitive voltmeters, voltmeters which themselves have been generally regarded as the industry standard. The specified range of the new voltmeter is from 10 hertz (cps) to 10 megahertz (Mc/s). This range is the more significant because, since the instrument is a voltmeter, its specified response represents the flat portion of the pass band rather than between 3-dB points. This fact, combined with the fact the voltmeter has a slow high-frequency roll-off beyond its flat region, gives a wide range indeed for many measurement situations (Fig. 3).

As to accuracy, the voltmeter typically measures within 1% over the full 10 Hz to 10 MHz region and is specified as within 1% over the central part of the range. The combination of this high accuracy and the extended frequency range is the result of the use of 'hot carrier' diodes<sup>1</sup> in the meter rectifier circuit and of the use of other solid-state devices in the overall circuit.

Another major advance incorporated in the voltmeter is a ground-referenced dc output system, a capability that has not generally been included in *-hp-* sensitive-type ac voltmeters. The dc output voltage is proportional to the meter reading, thus enabling the voltmeter to be used as a 10 Hz — 10<sup>+</sup> MHz ac-dc converter.

<sup>1</sup> Hans O. Sorensen, "Using the Hot Carrier Diode as a Detector," *Hewlett-Packard Journal*, Vol. 17, No. 4, Dec., 1965.

Fig. 1. Author Reid Gardner here checks accuracy of new *-hp-* Model 400E AC Voltmeter using special calibration set-up. New voltmeter has 1% accuracy over much of its 10 Hz-10 MHz range.

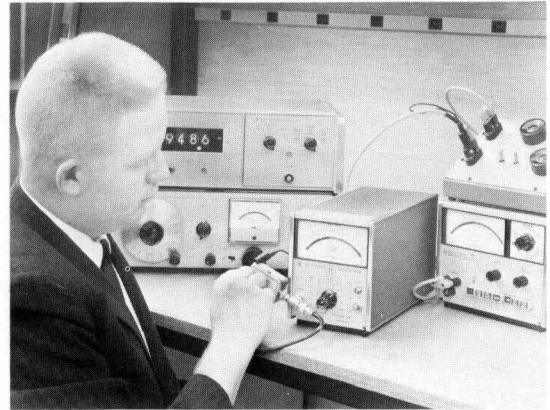

Many situations requiring dc drive signals from ac signals are greatly simplified by this capability. The dc output is a high-accuracy output and its characteristics are carefully described in the instrument specifications. Beside the dc output, the ac output that has been characteristic of *-hp-* ac voltmeters is also included.

Other new components have permitted other design advances. A field-effect transistor in the voltmeter front end has resulted in the combination of low noise (< 15  $\mu$ V) and high input impedance (10 megohms), while metal film resistors in the gain-determining circuits together with other measures give very high overall stability. The voltmeter is stable, for example, to the extent that a change in ambient temperature from 25°C to 0°C typically causes less than 0.3% change in reading. The instrument can also be operated in ambients to +55°C with little change in accuracy.

A final new capability worthy of mention is that the voltmeter can be operated from batteries without special modification.

Overall, the measuring range of the instrument is from below 50 microvolts to 300 volts in 12 ranges, the most sensitive being 1 millivolt full scale. The circuitry is fully solid-state.

## FREQUENCY RESPONSE

The broad frequency response of the new voltmeter is shown in Fig. 3. These curves are plots of the voltmeter's dc output voltage with a constant amplitude ac voltage of varying frequency at the input. The curve at left is plotted on the conventional dB scale and shows that the frequency response of a typical Model 400E Voltmeter is nearly indistinguishable from a straight line from 10 Hz to 10 MHz. However, the useful frequency range

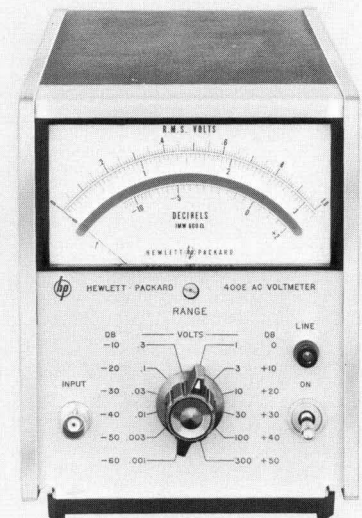

Fig. 2. *-hp-* Model 400E Voltmeter has taut-band meter movement with individually-calibrated scales.

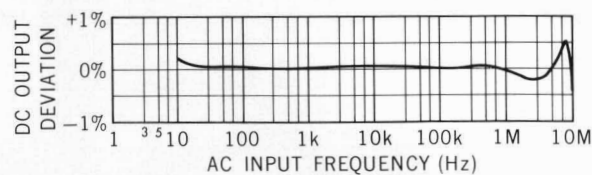
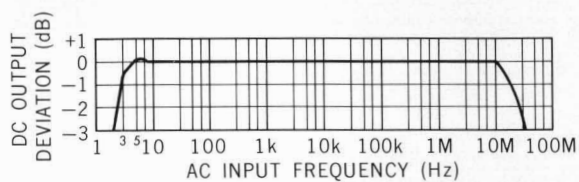

Fig. 3. Typical frequency response of new voltmeter (monitored at dc output) plotted with logarithmic vertical scale (left curve). 3-dB points are typically at 2 Hz and 35 MHz. Curve at right

is with expanded vertical scale, showing that typical deviations do not exceed  $\pm 1/2\%$  within rated passband of instrument.

extends well beyond these limits, the 3-dB points being typically at 2 Hz and 35 MHz.

The right curve of Fig. 3 shows the frequency response plotted on a greatly expanded vertical scale that exaggerates minor perturbations. This plot shows that the typical response within the rated passband of the voltmeter deviates only 0.5% of reading at full scale, and this is at 8 MHz. Within the range of 100 Hz to 1 MHz, the response deviates no more than a small fraction of 1%.

#### STABILITY

A stability-with-time plot typical of the new voltmeter is shown by the curves in Fig. 4. This is a graph of the dc output of the Model 400E Voltmeter with a stabilized 1-volt, 1-kHz signal at the input. As shown on the greatly expanded vertical scale here, deviations as a function of time are of a very low order. The turn-on warm-up effect itself causes less than 0.2% error, and this lasts for only a few minutes. Following a 1-hour warm-up period, drift is typically less than 0.02%/hour. A typical instrument has shown less than 0.1% drift in three months use in a typical laboratory environment.

The high stability of the new voltmeter is also maintained in spite of line voltage changes. A change from 10% low line voltage to 10% high results in no change in the dc output as monitored by a 4-place digital voltmeter.

#### TAUT-BAND METER

A major contribution to the accuracy of the new voltmeter comes from the use of an individually-calibrated, taut-band meter. Each meter has a  $4\frac{1}{2}$ -inch mirror-backed scale that is calibrated for that meter movement with the *-hp-* designed servo meter calibrator.<sup>2</sup> A

<sup>2</sup> Bernard M. Oliver, "Increased Accuracy in *-hp-* Meters Through Servo Calibrating Methods," *Hewlett-Packard Journal*, Vol. 12, No. 7, Mar., 1961.

meter accuracy of 0.25% on the linear voltage scales ordinarily is achieved by this method, approaching the accuracy that otherwise can only be achieved by hand calibrating.

#### METER SCALES

The basic meter face for the voltmeter is one that is calibrated with two linear voltage scales and a dB scale, as shown in Fig. 5a. The two voltage scales together with range switching in a 1-3-10 sequence enable readings to be made on the upper two-thirds of the meter for highest accuracy. The range steps are each equal to 10-dB, so that only one dB scale is necessary.

A meter face with the dB scale on the outermost circumference has also been designed to permit greater resolution in dB measurements (Fig. 5b).

A logarithmic meter movement that uses a linear dB scale has been designed for the Model 400EL Voltmeter, an instrument that is otherwise identical to the Model 400E. The linear dB scale (Fig. 5c) is often preferred by communications engineers and others who make measurements primarily in dB units. (The dc output of this voltmeter has the same linear response as the Model 400E.)

#### DC OUTPUT

Previous sensitive-type ac voltmeters have not had dc outputs proportional

to meter deflection, primarily because the meter was included in the ac feedback path and was not at ground potential. The new voltmeter uses a meter circuit that isolates the meter itself from the feedback path, permitting the derivation of a dc output proportional to deflection (1 volt max. at 1 mA).

The new voltmeter may thus be used to drive a graphic recorder directly for long-term monitoring of ac voltages. It may also serve as a low-cost ac-to-dc converter for use with digital voltmeters or wherever there is a need for a dc voltage proportional to a given ac voltage. The ac-to-dc conversion, as measured at the dc output, is accurate within  $\pm 1/2\%$  within a frequency range of 100 Hz to 500 kHz and within 1% over a much broader range.

The wide dynamic response of the new voltmeter enables it to serve as an ac-to-dc converter over a dynamic range of 50 dB on any one setting of the range switch above the 3-mV range (the input noise tends to reduce the dynamic range on the 1- and 3-mV ranges). The error at 40 dB below full scale, on the 1-V range, is typically less than 10% of reading between 200 Hz and 400 kHz and at 30 dB below, it is typically less than 4%. The transient response of the converter is shown by the oscillogram of Fig. 6.

The dc output (on the rear panel), when connected to a digital voltmeter,

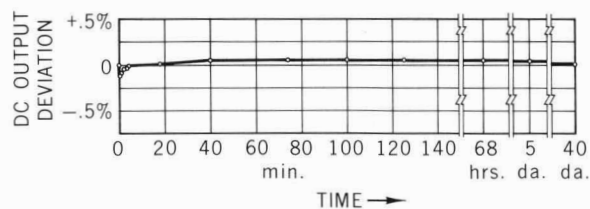
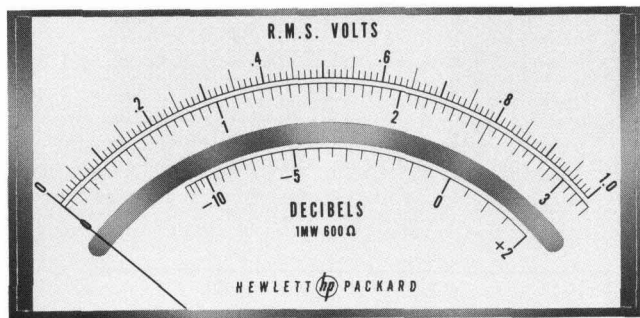
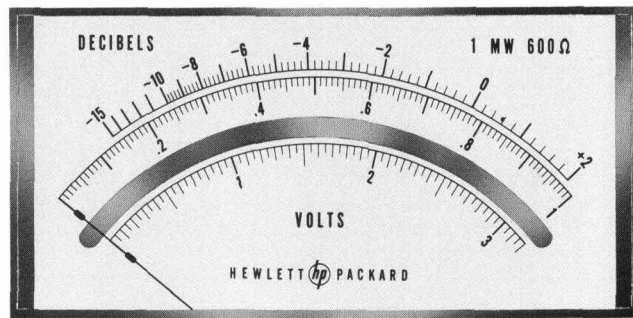

Fig. 4. Typical stability of *-hp-* Model 400E/EL AC Voltmeter is shown by plot of readings taken at voltmeter dc output while accurately monitored sine wave is applied to input. Plot shows that stability of voltmeter following 1-hour warm-up period is typically better than 0.02%/hour. Drift has been less than 0.1%/month in typical instruments.



(a)



(b)

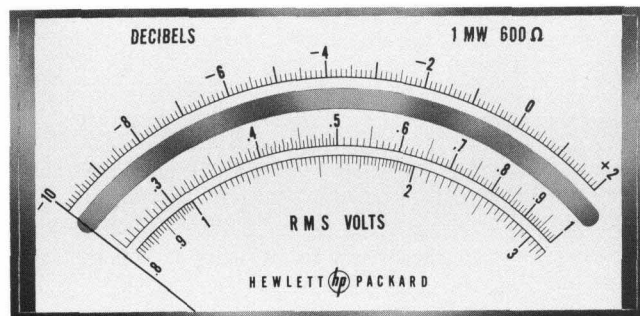

(c)

Fig. 5. Meter scale normally supplied with *hp*-Model 400E AC Voltmeter, with 100 divisions in high resolution upper scale, is shown at top (a). Optional meter face (b) has longer dB scale on outermost arc for higher resolution in dB measurements but retains linear voltage scales. Model 400EL Logarithmic Voltmeter has logarithmic voltage scales but dB scale is linear, as shown by meter face at (c).

is also useful for obtaining high resolution readings, particularly when small changes in an ac voltage are to be monitored.

#### AC OUTPUT

The new voltmeter also has a rear panel ac output which enables it to serve as a preamplifier or impedance converter. The ac output impedance is 50 ohms and full scale output voltage into an open circuit is 150 mV rms (105 mV on the 1-mV range). The instrument uses a buffer amplifier to couple the main amplifier feedback signal to the output and distortion caused by diode crossover is thus reduced to negligible proportions at midband frequencies, as shown in the oscillogram of Fig. 7a. At higher frequencies, how-

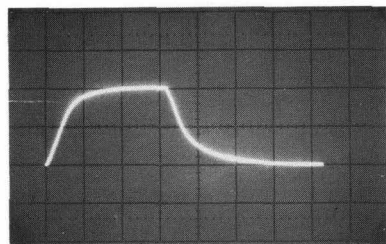

Fig. 6. Typical transient response of new voltmeter as ac-to-dc converter, monitored at dc output, with gated 100-mV, 400-Hz sine wave at input. Vertical scale is 0.5V/cm; horizontal scale is 0.5s/cm.

ever, the reduction in amplifier gain causes the crossover distortion to become noticeable, as shown in the oscillogram of Fig. 7b.

Fig. 8 shows the input and output waveforms of the new voltmeter when driven by a 1-MHz square wave. This oscillogram illustrates the excellent transient response and good phase characteristics of the meter amplifiers.

#### ESTABLISHING PERFORMANCE SPECIFICATIONS

Specifying the performance of an instrument that functions over both a wide frequency range and a wide dynamic range usually requires several compromises. Full specification of the performance for each combination of measurement conditions leads to an unwieldy list of numbers whereas streamlined specifications generally lead to an understatement of the instrument's best capabilities while reducing the amount of performance data available to the user.

The technique used to specify the accuracy of the new voltmeters combines 'three-dimensional' information into two dimensions (see Specifications). The horizontal scale on the specification charts corresponds to frequency, and the vertical scale represents signal amplitude. The numbers in each box represent the error limits that may be encountered for that par-

ticular combination of amplitude and frequency. A first approximation to the maximum errors that may be expected at any scale position can be had by interpolating linearly between the scale points shown.

The new format shows that there is a broad frequency range where measurement accuracies of better than 1% of reading may be obtained with the new voltmeters. As ac-to-dc converters, the voltmeters have an accuracy of  $\pm 1/2\%$ , as measured at the dc output, within a frequency range of 100 Hz to 500 kHz.

#### CIRCUIT DESCRIPTION

A simplified block diagram of the new voltmeters is shown in Fig. 9. As in previous ac voltmeters, the signal is applied either directly to the impedance converter or it is attenuated 50 dB in the input attenuator (on the 3-V and higher ranges). To prevent stray coupling between the input attenuator and the other circuits, the input attenuator is separately shielded and is switched by reed relays. Care has been taken with the signal and ground paths to assure high accuracy up to 300 volts at 10 MHz.

The impedance converter includes a field-effect transistor connected as a low-noise 'source-follower' that has an effective input impedance of 1000 megohms. This is followed by one amplifier stage and an emitter-follower, all enclosed in a feedback loop that

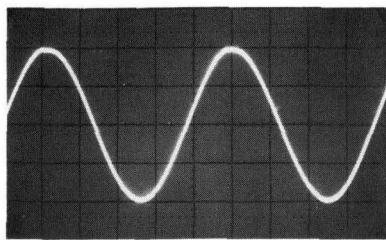

(a)

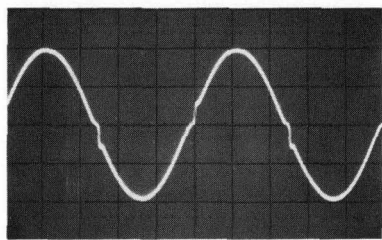

(b)

Fig. 7. AC output of new voltmeter with full scale input voltage. Trace at left results from 400-Hz sine wave at voltmeter input. Trace at right, with 1-MHz sine wave at input, shows crossover distortion.

achieves an overall converter gain of 1 and an output impedance of 2 ohms. The impedance converter effectively isolates switching in the post attenuator from the input circuits.

The voltmeters offer wide overload protection and quick recovery from overloads by the use of signal clamping techniques at the input. Recovery from a large dc transient (600 volts) on the 1-mV range is less than 10 seconds, and recovery on other ranges is proportionally less. Recovery from ac overloads is essentially instantaneous.

The post attenuator is a 600-ohm ladder attenuator that changes attenuation in 10-dB steps from 0 to 50 dB. With the input and post attenuators working together, the signal ranges can be changed from 3 mV full scale to 300 V full scale. The 1-mV range is obtained by increasing the amplifier gain by 10 dB.

The amplifier drives the meter rectifier circuit from which a negative feedback signal is fed back to the amplifier input to stabilize gain. With the large amount of the feedback designed into the amplifier, the overall gain of the amplifier is determined primarily by the precision metal-film resistors in

the feedback network. Together with the use of regulated power supplies, the feedback also assures the high stability of the voltmeters.

The ac feedback signal is also fed through the unity-gain buffer amplifier to the AC Output connector on the rear panel. The buffer amplifier serves as an impedance converter that isolates the feedback signal from the output. Shorting the output has no effect on the meter reading.

#### THE RECTIFIER CIRCUIT

The meter rectifier circuit incorporates several refinements which lead to greater flexibility and improved performance in the new voltmeter. To place these refinements in perspective, let us review the rectifier circuit commonly used in previous ac voltmeters.

A simplified diagram of the earlier circuit is shown in Fig. 10(a). As the arrows in the diagrams show, the diodes act as switches to guide the current through the meter unidirectionally. In contrast with peak-reading voltmeters, in which the rectifier diode conducts only during the peak portion of the waveform, the diodes here each conduct for a full half cycle and the ballistic characteristics of the meter

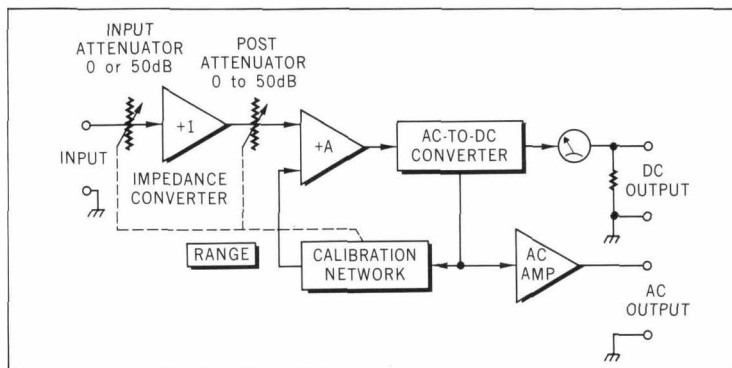

Fig. 9. Block diagram of *-hp-* Model 400E/EL AC Voltmeters.

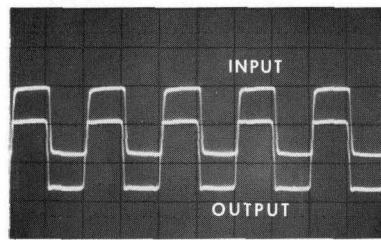

Fig. 8. Typical transient response of voltmeter amplifier is shown by dual trace oscillogram of voltmeter input and output. Test signal is 1-MHz square wave.

smooth the meter response to the current pulses. The meter deflection is thus proportional to the average value of the driving waveform.<sup>3</sup>

The rectifier circuit in the new 400E/EL voltmeters is shown in Fig. 10(b). The meter has been replaced here by a transistor that establishes a virtual short circuit across the corners of the bridge without allowing current to flow directly from corner to corner. The current is coupled out of the bridge through the collector circuit of the transistor, and back again through

<sup>3</sup> B. M. Oliver, "Some Effects of Waveform on VTVM Readings," *Hewlett-Packard Journal*, Vol. 6, No. 8, Apr., 1955.

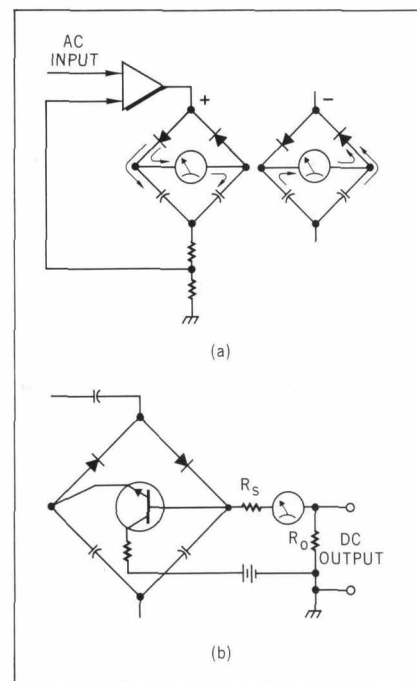

Fig. 10. Conventional average-responding meter rectifier circuit is outlined in (a). Arrows show current paths for both half-cycles of input waveform. New meter circuit is shown in (b). Current paths are similar to (a) except that meter current is brought to ground reference by means of transistor and isolating resistor  $R_s$ .

the meter and isolating resistor  $R_s$ . The meter current may thus be referenced to ground, and a common-ground connection may be established between the ac input and dc output of the voltmeter. Furthermore, the meter is isolated from the feedback path so that RF radiation from the meter in high-frequency measurements is reduced significantly and there is little danger of a radiated feedback path from meter to input. The instrument is also less susceptible to RFI since interference that may be picked up by the meter is grounded before it can affect other circuits.

Resistor  $R_o$  in series with the meter provides the dc output voltage. Since the meter is driven by a current source, any impedance—even a short circuit—may be connected to the output without affecting the meter reading.

#### ENVIRONMENTAL TESTS

The design of the new voltmeters has been proved in a series of environ-

mental tests, including such tests as temperature variations, humidity, vibration, and RFI. The tests have shown that the Model 400E/EL Voltmeters, as ac-to-dc converters, have an output deviation typically less than 0.1% within a frequency range of 100 Hz to 1 MHz, when the temperature is changed from 25°C to 55°C. From 25°C to 0°C the deviation is less than 0.2% on the ranges below 3 V and less than 0.3% on the 3-V ranges and above. There were no failures in the vibration and humidity tests.

#### BATTERY OPERATION

Terminals on the rear panel are connected to the inputs of the voltage regulators in the voltmeter's internal power supplies. The voltmeter may therefore be powered by batteries, two being required, capable of supplying 54 mA each at 35 to 55 volts. The voltmeter may thus be completely freed from ground interconnects, if ground loops are a problem. Or, the voltmeter can be operated on batteries in the field where ac power may not be readily available.

#### MODIFICATION OF THE BASIC DESIGN

To accommodate various requirements in voltmeter measurements, modifications have been designed for

the new voltmeters. In one, a potentiometer control, concentric with the RANGE switch, has been added. When turned from the detented ABSOLUTE position, this control reduces the sensitivity of the meter circuit so that the operator may offset the pointer to a major meter division to serve as a reference mark (while the voltmeter is measuring a reference voltage). The relative gain or loss in a circuit being measured is thus easily interpreted with respect to the reference voltage.

Some applications, such as filter design, require constant input capacitance on all ranges. Normally, the voltmeter input capacitance is lower on the ranges above 1 volt (8 pF) than it is on the 1-V range and below (21 pF). This arrangement is usually preferred since the input current at high frequencies is primarily a function of the input capacitance. However, if the voltmeter is to be used over a wide range in applications in which the tuning of a circuit is affected by the voltmeter capacitance, the capacitance can be made constant (22 pF) on all ranges. A 10-to-1 low-capacitance passive probe is also being designed for instruments with this modification to reduce the input capacitance at the point of measurement.

**SPECIFICATIONS**

-hp- MODELS 400E and 400EL

**AC VOLTMETERS**

**VOLTAGE RANGE:** 1 mV to 300 V full scale, 12 ranges in 10-dB steps.

**FREQUENCY RANGE:** 10 Hz to 10 MHz.

**CALIBRATION:** Reads rms value of sine wave; voltage indication proportional to absolute average value of applied waveform.

**SCALES:** Model 400E: Linear voltage scales, 0 to 1 and 0 to 3.2; dB scale, -12 to +2 dB. Model 400EL: Logarithmic voltage scales, 0.25 to 1 and 0.8 to 3.2; linear dB scale, -10 to +2 dB.

**ACCURACY** (as % of reading): See tables below right.

**INPUT IMPEDANCE:** 10 megohms shunted by 21 pF on 1 mV to 1 V ranges and 10 megohms shunted by 8 pF on 3 V to 300 V ranges.

**AC OUTPUT:** 150 mV rms for full scale meter indication (105 mV on 1 mV range); output impedance: 50 ohms, 10 Hz to 10 MHz.

**AC-DC CONVERTER OUTPUT:** 1 Vdc output for full scale meter deflection.

**OUTPUT RESISTANCE:** 1000 ohms.

**RESPONSE TIME:** 1 sec to within 1% of final value for step change of input ac.

**AC POWER:** 115 or 230 volts  $\pm 10\%$ , 50 to 1000 Hz; approx. 5 watts.

**TEMPERATURE RANGE:** 0 to +55°C.

**EXTERNAL BATTERY OPERATION:** Terminals provided on rear panel; positive and negative voltages between 35 V and 55 V are required; current drain from each voltage is approx. 54 mA. (External switching and on/off monitoring should be used for battery operation.)

**WEIGHT:** Net 6 lbs. (2.7 kg), Shipping 9 lbs. (4 kg).

**DIMENSIONS:** 6½" high, 5½" wide, 11" deep (165,1 x 130,2 x 279,4 mm).

**PRICE:** Model 400E, \$285.00; Model 400EL, \$295.00.

Option: 01 (400E only) reads directly in volts and dB with dB scale uppermost. \$10.00.

Option: 02 (400E or 400EL) front panel relative control. \$10.00.

**HO5-400E/EL:** Constant input capacity (10 megohms shunted by 22 pF). Price on request.

Prices f.o.b. factory.  
Data subject to change without notice.

-hp- MODEL 400E (ACCURACY % Of Reading)

3 mV-300 V RANGES	AT FULL SCALE	$\pm 4$	$\pm 2$	$\pm 1$	$\pm 2$	$\pm 4^*$
	AT 1/3 FULL SCALE	$\pm 4$ -10	$\pm 3$ -5	$\pm 3$	$\pm 3$ -4	$\pm 3$ -5
	AT 1/10 FULL SCALE	$\pm 4$ -10	$\pm 2$	$\pm 1$	$\pm 2$	$\pm 4$ -10
1 mV RANGE	AT FULL SCALE	$\pm 4$	$\pm 3$	$\pm 3$	$\pm 3$ -4	$\pm 3$ -5
	AT 1/3 FULL SCALE	$\pm 4$ -10	$\pm 3$ -5	$\pm 3$	$\pm 3$ -4	$\pm 3$ -5
	AT 1/10 FULL SCALE	$\pm 10$ -20	$\pm 10$ -15	$\pm 10$	$\pm 10$ -10	$\pm 10$ -30
Frequency:		10	20	40	100 Hz	1 MHz
					0.1	0.2
					0.5	1
					2	4
					6	10

-hp- MODEL 400EL (ACCURACY % Of Reading)

3 mV-300 V RANGES	AT FULL SCALE	$\pm 4$	$\pm 2$	$\pm 1$	$\pm 2$	$\pm 4^*$
	AT 1/3 FULL SCALE	$\pm 4$ -10	$\pm 2$ -4	$\pm 1.5$	$\pm 2$	$\pm 2$ -4
	AT 1/10 FULL SCALE	$\pm 4$ -10	$\pm 2$	$\pm 1$	$\pm 2$	$\pm 4$ -10
1 mV RANGE	AT FULL SCALE	$\pm 4$	$\pm 2$	$\pm 1.5$	$\pm 2$	$\pm 4$
	AT 1/3 FULL SCALE	$\pm 4$ -10	$\pm 2$ -4	$\pm 1.5$	$\pm 2$	$\pm 3$ -10
	AT 1/10 FULL SCALE	$\pm 4$ -10	$\pm 2$	$\pm 1.5$	$\pm 2$	$\pm 3$ -10
Frequency:		10	20	40 Hz	1 MHz	0.2
					0.5	1
					2	4
					6	10

AC-to-DC Converter output (ACCURACY % Of Reading)  
-hp- MODELS 400E and 400EL

3 mV-300 V RANGES	AT FULL SCALE	$\pm 4$	$\pm 2$	$\pm 1$	$\pm 0.5^{**}$	$\pm 1$	$\pm 2$	$\pm 4^*$
	AT 1/3 FULL SCALE	$\pm 4$ -10	$\pm 2$ -4	$\pm 1$	$\pm 1$	$\pm 2$	$\pm 2$ -4	$\pm 3$ -10
	AT 1/10 FULL SCALE	$\pm 4$ -10	$\pm 2$	$\pm 1$	$\pm 0.5^{**}$	$\pm 1$	$\pm 2$	$\pm 4$ -10
1 mV RANGE	AT FULL SCALE	$\pm 4$	$\pm 2$	$\pm 1$	$\pm 1$	$\pm 2$	$\pm 2$	$\pm 3$
	AT 1/3 FULL SCALE	$\pm 4$ -10	$\pm 2$ -4	$\pm 1$	$\pm 1$	$\pm 2$	$\pm 2$ -4	$\pm 3$ -10
	AT 1/10 FULL SCALE	$\pm 4$ -15	$\pm 4$ -10	$\pm 4$	$\pm 4$	$\pm 4$ -10	$\pm 4$ -15	$\pm 4$ -30
Frequency:		10	20	40 Hz	1 MHz	0.1	0.2	0.5
					1	2	4	10

\* +4 and -10% on 100 and 300V ranges  
\*\* For 15°C - 40°C on 1 mV-1 volt ranges only

## DESIGN LEADERS

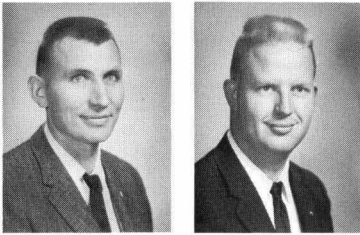

Lionel Kay Danielson Reid Gardner

Kay Danielson joined the Hewlett-Packard Microwave Division as a test engineer in 1959 after graduating with a BSEE degree at Utah State University. He transferred to the -hp- Loveland Division as a product design engineer in 1963. At Loveland, Kay has been responsible for the product design of the -hp- Models 651A Test Oscillator, 465A Amplifier, 331A Distortion Analyzer, and the soon-to-be-announced 427A Multifunction Meter. He is also responsible for the product design of the Model 400E/EL Voltmeter discussed herein.

Reid Gardner graduated from Utah State University with a BSEE degree in 1960 and subsequently worked as a consultant engineer with a power company. Later, he returned to Utah State as an instructor on the Electrical Engineering faculty and also attended classes working towards an advanced degree. He also did summer work in industry on special design problems.

Reid obtained his MSEE from Utah State in 1963, after which he joined the -hp- Loveland Division as a Development Engineer. His first assignment was doing development work on the -hp- Models 331A and 332A Distortion Analyzers. More recently, he has been working on broadband precision ac voltmeters and has been the project engineer for the Model 400E/EL voltmeter series described in this issue.

Reid is a member of Sigma Tau and of the IEEE. He also served as student counselor for the AIEE while an instructor at Utah State.

## ACKNOWLEDGMENTS

The electrical design of the Models 400E and 400EL Voltmeters was performed by the undersigned with many ideas and helpful suggestions provided by Terry E. Tuttle, Development Engineer; Charles R. Moore, Group Leader; and Marco Negrete, Engineering Manager of the -hp- Loveland Division. Product design was by Lionel Kay Danielson. The meter circuit was conceived by Gregory Justice of the -hp- Advanced Research and Development Laboratories in Palo Alto.

-Reid J. Gardner

# MEASUREMENT OF LIQUID LAYER THICKNESS WITH TIME DOMAIN REFLECTOMETRY

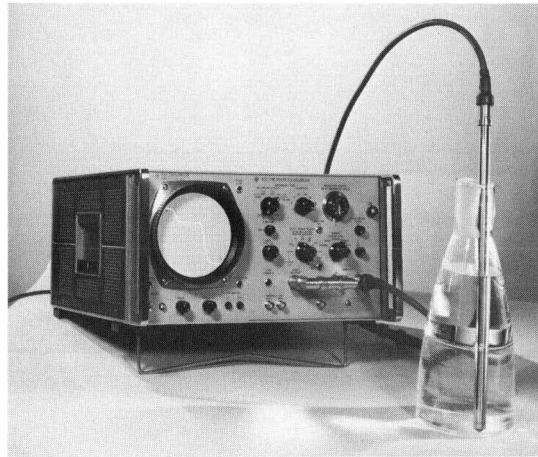

Fig. 1. TDR System for liquid layer depth measurements consists of standard -hp- Model 140A/1415A Time Domain Reflector with section of rigid air-dielectric coaxial line serving as probe. Slots cut in outer conductor of probe admit liquids which alter impedance of coaxial line wherever there is a change in liquid dielectric constant.

THE PULSE-ECHO techniques of time domain reflectometry have already proven useful in many electrical measurements, such as in the design and test of transmission line, coaxial cable, and antenna systems.<sup>1</sup> Now, the ability of time domain reflectometry to resolve electrical distance, reflection coefficient, and impedance mismatch also shows promise of having important chemical applications.

Since many liquids exhibit dielectric behavior, it is possible to identify a change in chemical composition by measuring the response of a TDR system to a change in dielectric constant. This is easily done by perforating the outer conductor of an air dielectric line and inserting the line in the liquids to be measured. The liquids thus become the dielectric of the line, and wherever there is an interface between two layers of liquids with differing dielectric constants, there results an identifiable reflection on the TDR display.

As an example, the oscillogram of Fig. 2, made with the equipment set-up shown in Fig. 1, displays the reflection

resulting from the interface of toluene floating on de-ionized water. Two "steps" are shown: one resulting from the reflection at the dielectric interface between air and toluene, and the second from the interface between toluene and water. The horizontal distance between the steps on the display corresponds to the thickness of the toluene layer, and the depth of the steps corresponds to the change in dielectric constant.

The TDR technique is capable of measurements of liquid layer depth and dielectric constant with two-place

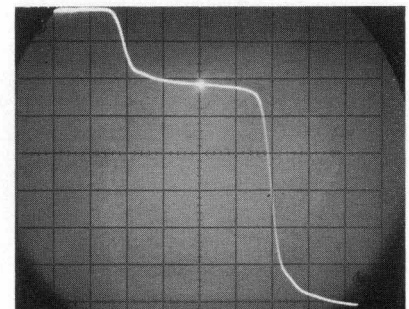

Fig. 2. Oscillogram displays response of TDR System to change in liquid dielectric constant. First step results from interface between air and toluene. Second step is caused by interface between toluene and de-ionized water. Horizontal sweep calibration is 6 cm of air line per cm of display. Dot corresponds to 'delay' dial setting.

<sup>1</sup> "Cable Testing with Time Domain Reflectometry," *Hewlett-Packard Journal*, Vol. 16, No. 12, Aug., 1965.

B. M. Oliver, "Time Domain Reflectometry," *Hewlett-Packard Journal*, Vol. 15, No. 6, Feb., 1964.

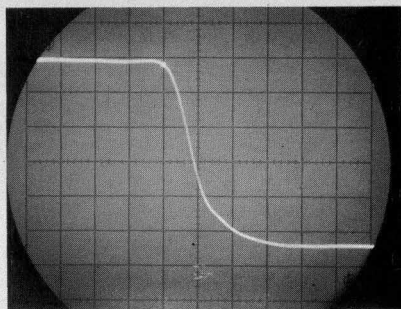

Fig. 3. Reflection from interface between air and industrial grade isopropanol. Dielectric constant of isopropanol can be derived from height of step, using equation 2 in text. Vertical calibration is  $0.1 \rho/cm$ .

resolution (dielectric losses, which slow the risetime of the reflected voltage steps, presently limit the resolution in liquids). The wide measurement range of the  $-hp-$  Model 1415A Time Domain Reflectometer<sup>2</sup> allows this technique to be used in a variety of situations. For instance, the "liquid dielectric" probe could be lengthened several feet to permit location of the liquid layers in a cracking tank, allowing each layer to be tapped with certainty. The depth and location of each layer would be indicated by the distance between reflections on the TDR scope. TDR could also detect the water level in a fuel storage tank, measure liquid levels in the presence of foam or measure liquid levels at cryogenic temperatures. In addition, TDR could determine distribution gradients in solutions or detect when certain reactions have gone to completion, the latter shown by the disappearance of the reflection resulting from a dielectric interface—an otherwise difficult task to perform by visual inspection when nonsoluble reagents have the same color.

#### COMPUTING DISTANCE IN LIQUIDS

The speed of propagation of an electromagnetic wave in a coaxial

<sup>2</sup> Lee R. Moffitt, "The Time Domain Reflectometer," *Hewlett-Packard Journal*, Vol. 15, No. 1, Sept., 1963.

TABLE 1.  
DIELECTRIC CONSTANTS OF ALCOHOLS

1 — Propanol	20.1
2 — Propanol	18.3
Methanol	32.63
Ethanol	24.30
1 — Butanol	15.8
2 — Butanol	17.1

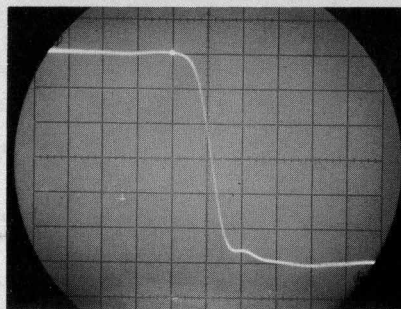

Fig. 4. Reflection from interface of air and industrial grade methanol (5% isopropanol). Vertical calibration is  $\rho = 0.1/cm$ . Height of step indicates higher dielectric constant than isopropanol (see Fig. 3).

cable, and hence the round-trip travel time of the voltage step in a TDR system, depends upon the dielectric constant of the dielectric material.

The  $-hp-$  Model 1415A Time Domain Reflectometer is calibrated to read distances in both air dielectric and polyethylene-filled cables. The distance  $D$  to an impedance discontinuity in any other dielectric may be computed by use of the formula:

$$D = \frac{D_A}{\sqrt{\epsilon}} \quad (1)$$

where  $D_A$  is the distance that the measured pulse round trip would indicate for an air dielectric cable and  $\epsilon$  is the relative dielectric constant of the actual material. The constant  $\epsilon$  can be found in a chemical handbook, if the substance is known.

In Fig. 2, the horizontal scale is 6 cm of coaxial line per cm of display. The "shelf" representing toluene is 4 cm, measured between the midpoints of the steps. The value of  $\epsilon$  for pure toluene is 2.4 at room temperature and thus, by equation 1, the depth of the toluene layer is 15 cm.

#### UNKNOWN DIELECTRICS

If the substance is not known, the dielectric constant can be found by determination of the reflection coefficient  $\rho$  through measurement of the amplitude of the reflected step. The dielectric constant is then:

$$\epsilon = \left( \frac{1 - \rho}{1 + \rho} \right)^2 \quad (2)$$

It is thus possible to identify liquids by measuring the reflection coefficient.

Referring again to Fig. 2, the first step represents the transition from air to toluene. The vertical deflection is calibrated such that 10 cm represents  $\rho = 1$  and, since the step downward from air to toluene is 2.2 cm,  $\rho = -0.22$ . Hence, by equation 2,  $\epsilon = 2.4$ .

The technique is useful for identifying liquids in a group if the dielectric constants differ significantly. However, as a technique for positively identifying an unknown liquid, the method is limited by the resolution available since the dielectrics of many liquids differ by as little as 1 part in 10,000.

TDR, however, is useful for identification of liquids within a specific group. The alcohols are one such group, identification by physical properties being difficult because of the similarities of color and smell. Fortunately, dielectric constants among the alcohols vary widely enough to permit good TDR resolution (see Table I). Fig. 3 shows the reflection at the interface of air and industrial isopropanol. The vertical calibration here is  $0.1 \rho/cm$ , and thus  $\rho = -0.55$ . From this,  $\epsilon = 16$ . Fig. 4 is the reflection from the interface of air and industrial grade methanol (5% isopropanol). Here,  $\rho$  is read as  $-0.60$  and thus  $\epsilon$  is 22.

—James Brockmeier  
Applications Engineer

### STRATOSPHERIC WARMING

A number of readers have inquired about the meaning of the term 'stratospheric warming,' which was listed here recently among the geophysical alerts in the hourly schedules of NBS standard broadcast stations WWV and WWVH.\* Stratospheric warming is included in the broadcast schedule at the request of meteorologists, although it is not a geophysical alert as such. Stratospheric warming usually occurs in late winter and is evidenced by the sudden warming of pockets of air from the normal  $-40$  to  $-70^\circ\text{C}$  temperature to near  $0^\circ\text{C}$  at altitudes from 40,000 to 60,000 feet. The pockets migrate over the globe with possible effects on the weather. When such a pocket is detected, usually by radiosonde, the 'Stratospheric warming' alert is included in the WWV/WWVH broadcasts so that meteorological research stations may be advised of its existence.

\* "NBS Standard Frequency and Time Broadcast Schedules," *Hewlett-Packard Journal*, Vol. 7, No. 3, Nov., 1965.